

## 5 Knuckle Swing Clear Hinges

Standard Weight Plain Bearing “Swing Clear” Full Mortise

Steel – polished and plated or phosphated and prime coated for painting

F248 – (ANSI A8123)



- Equipped with easily seated non-rising pins
- Reversible flush tips and pins
- Ideal for remodeling or new construction
- Available for full mortise application on square edge doors only
- Designed to replace existing 3 1/2” (89mm) or 4” (102mm) hinges for Swing Clear openings (some modification of preparation may be required for residential use)
- Designed to swing doors completely clear of the opening when door is opened 95°

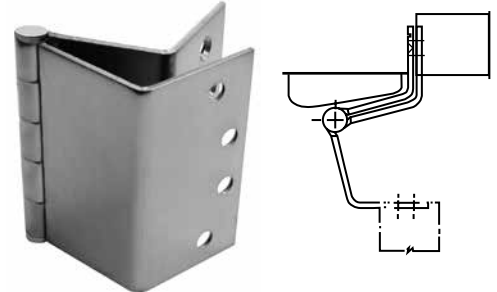

Class Number	Size Length of Joint		Gauge of Metal		Flat Head Screws/ Per Piece	Quantity Per Box	Quantity Per Case	Case Weight	
	Inches	(mm)	Inches	(mm)				Lbs.	(Kg)
F248	3 1/2	(89)	.123	(3.1)	6-10 x 1	2 ea.	20 ea.	16	(7)
	4	(102)	.130	(3.3)	8-12 x 1 1/4	2 ea.	20 ea.	24	(11)

## Standard Weight Ball Bearing “Swing Clear” Full Mortise

Steel – polished and plated or phosphated and prime coated for painting

Stainless steel – highly polished or satin finish

STSFBB248 – (ANSI A5122)

FBB248 – (ANSI A8122)

STSFBB258 – (ANSI A5122)

FBB258 – (ANSI A8122)



- Reversible flush tips and pins
- Ideal for remodeling or new construction
- Specify FBB248 and STSFBB248 for full mortise application on square edge doors
- Specify FBB258 and STSFBB258 for full mortise application on bevel edge doors
- Designed to swing doors completely clear of the opening when door is opened 90°
- Equipped with two Stanley permanently lubricated non-detachable ball bearings
- Hinges can be furnished with hospital tips (HT)

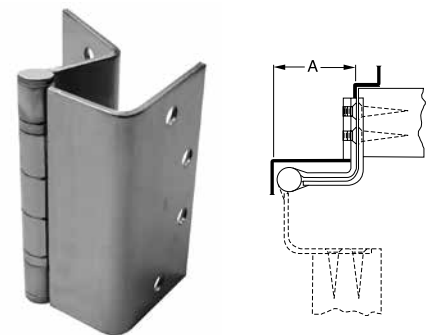

FBB248 (Shown) and STSFBB248  
{For square edge doors}

FBB258 and STSFBB258  
{For doors beveled 1/8” in 2” (3.2 in 51mm)}

Class Number	Size Length of Joint		Minimum Clearance Required Dimensions "A"		Gauge of Metal		Flat Head Screws/ Per Piece		Quantity Per Box	Quantity Per Case	Case Weight	
	Inches	(mm)	Inches	(mm)	Inches	(mm)	Frame Leaf Machine	Door Leaf Wood			Lbs.	(Kg)
FBB248, STSFBB248	4 1/2	(114)	2 1/8	(54)	.134	(3.4)	4-12-24 x 1/2	4-12 x 1 1/4	3 ea.	24 ea.	36	(17)
FBB258, STSFBB258	4 1/2	(114)	2 1/8	(54)	.134	(3.4)	4-12-24 x 1/2	4-12 x 1 1/4	3 ea.	24 ea.	36	(17)