

Wardrobe Pivots

340 – (ANSI A8753) – Standary duty – steel – plated or prime coated finishes

- For flush, recessed or overlay doors 1 1/8" (28.6 mm) to 1 3/8" (35 mm) thick not exceeding 75 lbs. (34 Kg)
- Only pivot of its type suitable for floor-to-ceiling doors
- Clean appearance, only hinge pivot shows when door is closed
- Door can be opened 180°
- Elongated screw holes make alignment simple
- Separable leaves of the top assembly permit fast installation
- Bushing at the pivot point assure smooth, silent operation

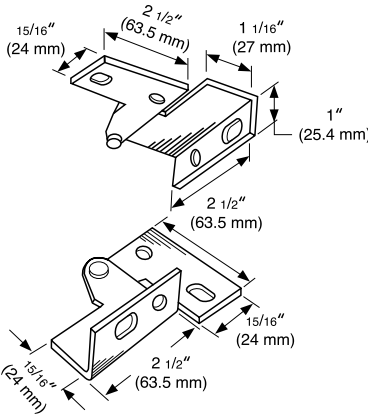
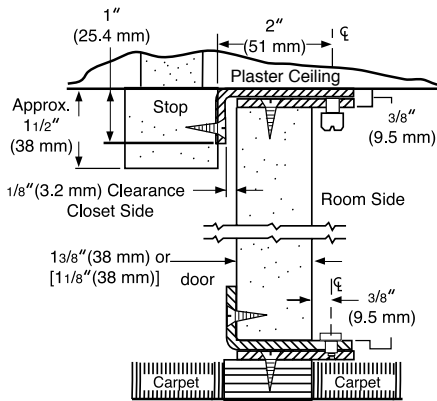

Right hand illustrated

Catalog Number	Gauge Inches	Gauge (mm)	Flat Head Wood Screws/ Per Set	Sets Per Box*	Sets Per Case	Case Weight Lbs.	Case Weight (Kg)
340	.131	(3.3)	8 - 12 x 3/4	1	20	17	(8)

*Set consists of one top hinge and one bottom hinge Handed. Specify right hand or left hand

341 – (ANSI A8773) – Standary duty – steel – plated or prime coated finishes

- For flush, or recessed doors 1 1/8" (28.6 mm) to 1 3/8" (35 mm) thick not exceeding 75 lbs. (34 Kg)
- Top header and bottom side frame mounted
- Suitable for floor-to-ceiling doors
- Door can be opened 180°
- Elongated screw holes for easy alignment
- Separable leaves of the bottom assembly for quick, easy installation
- Bushing at the pivot point assure smooth, silent operation
- Edge mortise door leaves – standard practice

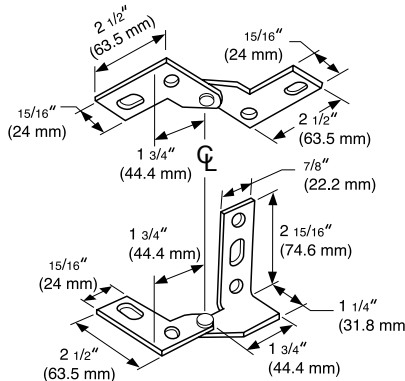
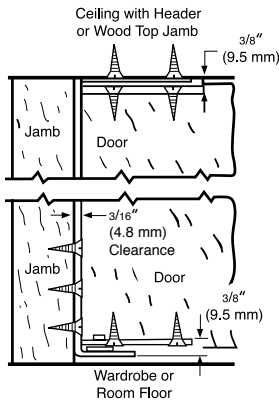

Right hand illustrated

Catalog Number	Gauge Inches	Gauge (mm)	Flat Head Wood Screws/ Per Set	Sets Per Box*	Sets Per Case	Case Weight Lbs.	Case Weight (Kg)
341	.131	(3.3)	7 - 12 x 1 2 - 12 x 1 1/4	1	20	14	(6.3)

*Set consists of one top hinge and one bottom hinge Handed. Specify right hand or left hand