

ALUMINUM CONTINUOUS GEARED HINGES



- 661 – Standard Duty for flush door and frame applications
- 661 HD – Heavy Duty for flush door and frame applications
- 662 – Standard Duty for 3/32" inset doors
- 662 HD – Heavy Duty for 3/32" inset doors

- Distributes door weight and stress along the full length of door and frame
- No misaligned pivot points of individual hinges
- Typically no additional reinforcement required
- Clear aluminum and dark bronze anodized finishes
- Standard duty and heavy duty conform to ANSI/BHMA Standard A156.26-1996, Grade 1
- LifeSpan® hinge covered by a limited lifetime warranty for the life of the building
- Engineered with polymer PTFE bearing for maximum durability
- 90-minute rating standard on all hinges. 3-hour rating available with fire pins (FP)

Hinges can be furnished as follows:

- with hospital tips (HT)
- with electric wires (CE)
- with electric switches (CS)
- with electric power transfer (EPT) prep – Specify manufacturer and model number of transfer
- with dutch door prep
- custom length

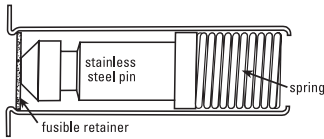

Fire Pin



661

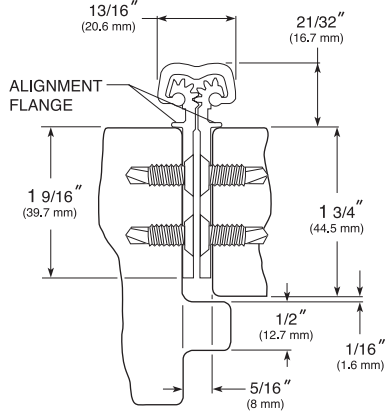

661/661HD Full Mortise
Flush Door & Frame



662

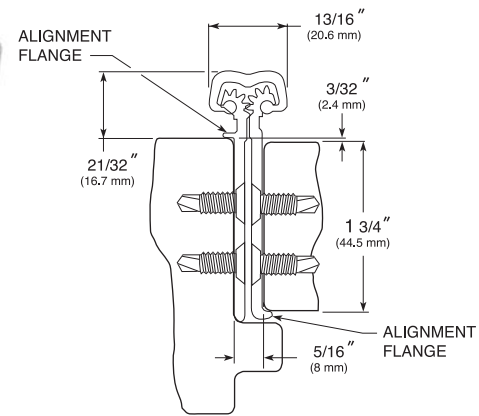

662/662HD Full Mortise
3/32" Inset

| Length | | Finish | Number of #12-24 x 5/8" TEK Screws Per Hinge | Quantity Per Carton | Carton Weight | |
|--------|--------|---------|---|------------------------|---------------|--------|
| Inches | (mm) | | | | Lbs. | (KG) |
| 79 | (2006) | AL & DB | 36 | 1 | 7 | (15.4) |
| 83 | (2108) | AL & DB | 36 | 1 | 7 | (15.4) |
| 95 | (2413) | AL & DB | 40 | 1 | 8 | (17.6) |
| 119 | (3022) | AL & DB | 44 | 1 | 10 | (22) |

Wood and Machine screws available separately

