

Triple Weight Concealed Ball Bearing Prison Hinges

BB852 – (ANSI A8391) – steel with welded pin. Phosphated and prime coated for painting

- For lead-lined doors to x-ray rooms and extremely heavy doors and gates
- For hinged cell-front doors and grated steel doors of penitentiaries, jails, reformatories, etc.
- Made of triple weight steel capable of carrying doors weighing up to 2000 lbs. (906 Kg)
(Based on a 3' x 7' door with 3 hinges)
- Each of the 2 concealed hardened steel races contains sixteen 3/16" (4.8 mm) hardened and ground steel balls which are assembled within a jacket
- Provision has been made in the barrel of the hinge for forced lubrication if further lubrication is necessary
- Typically made not swaged, no holes (application A) for full surface applications, or for full mortise (applications C) application. All other configurations are made to order

Rolled knuckles are welded and machined.

Pin is solid one piece steel welded at both ends making pin removal impossible.

Two concealed bearing assemblies. Hardened raceways. Hardened and ground balls.

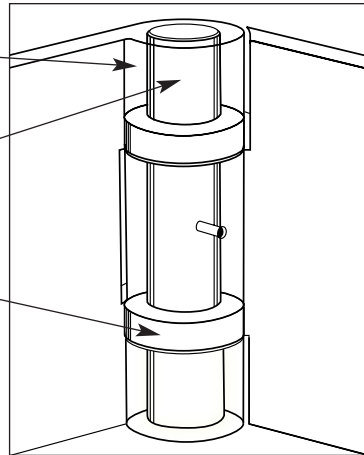

TYPICAL APPLICATIONS OF BB852

Regularly furnished blank no holes, not swaged for **Full Surface – application A**

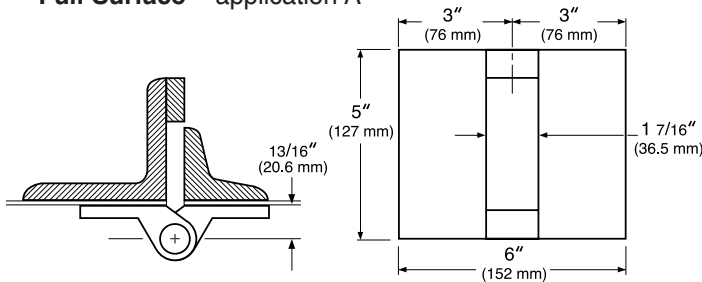

Full Surface with holes to template – application B

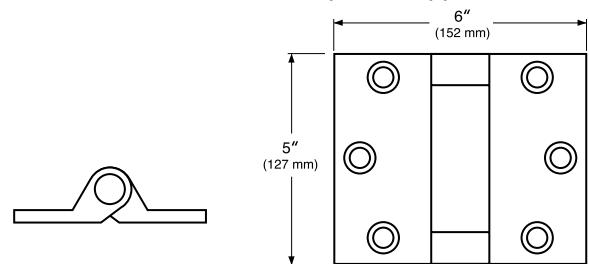

Full Mortise – applications

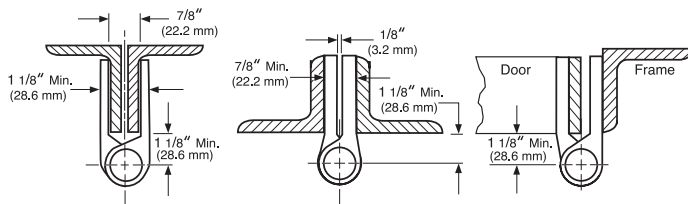

Application C
Not swaged

Application D
Swaged

Application E
Special swaged

For all full mortise applications the center of barrel should be set 1 1/8" (28.6 mm) from door and frame so welded joints will clear. Leaves can be swaged apart any distance between 1/8" (3.2 mm) to 7/8" (22.2 mm)

Half Mortise

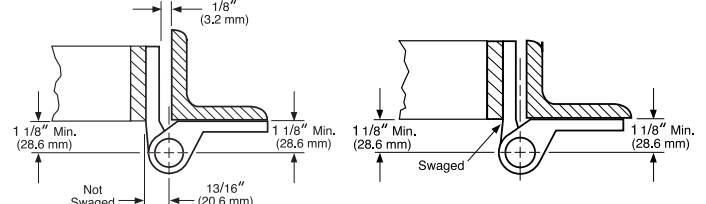

Application F
Half mortise

Application G
Half mortise

Variations of half mortise or half surface types can be obtained by further bumping or swaging of mortise leaf to accommodate any required construction. Specify hand when ordering

* Furnished on order with holes and with machine screws, at additional cost
If above details do not show your particular construction submit details and specifications

No holes, not swaged for applications "A" or "C"	Catalog Number	USP/EDP Number	Length of Joint		Width Open		Gauge of Metal		Diameter of Pin		Quantity Per Carton	Carton Weight
			inches	(mm)	inches	(mm)	inches	(mm)	inches	(mm)		Lbs. (Kg)
	BB852	02 9388	5	(127)	6	(152)	.375	(9.5)	3/4	(19.1)	2 Ea.	10 (4.5)