

## 2 Knuckle Full Mortise Heavy Weight Concealed Bearing **LifeSpan**®

**CB0701-** (ANSI A8111) – Steel – polished and plated or phosphated and prime coated for painting

**CB0761- (32)** – (ANSI A5111) – Stainless Steel – highly polished

**CB0761- (32D)** – (ANSI A5111) – Stainless Steel – satin finish

- For heavy doors, or doors where high frequency is expected
- Concealed bearing, takes both vertical and lateral loads
- Secure: Door cannot be lifted off when in closed position
- All hinges have template screw holes location for use on either wood or hollow metal doors and frames
- Loose joint – specify hand

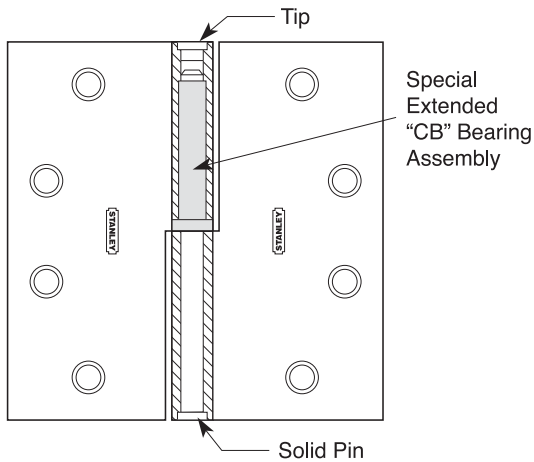

Class Numbers	Finish	EDP Number	Size Open		Gauge of Metal		Number of Flat Head Machine Screws Per Piece	Quantity		Carton Weight	
			Inches	(mm)	Inches	(mm)		Per Box	Per Carton	Lbs.	(KG)
CB0701-RH	P	83-4358	4 1/2"	114	.180	(4.6)	8 - 12 - 24 x 1/2	3 EA.	30 EA.	43	(19.5)
CB0701-LH	P	83-4382	4 1/2"	114	.180	(4.6)	8 - 12 - 24 x 1/2	3 EA.	30 EA.	43	(19.5)
CB0761-RH	32	83-4366	4 1/2"	114	.180	(4.6)	8 - 12 - 24 x 1/2	3 EA.	30 EA.	43	(19.5)
CB0761-LH	32	83-4390	4 1/2"	114	.180	(4.6)	8 - 12 - 24 x 1/2	3 EA.	30 EA.	43	(19.5)
CB0761-RH	32D	83-4374	4 1/2"	114	.180	(4.6)	8 - 12 - 24 x 1/2	3 EA.	30 EA.	43	(19.5)
CB0761-LH	32D	83-4408	4 1/2"	114	.180	(4.6)	8 - 12 - 24 x 1/2	3 EA.	30 EA.	43	(19.5)

\* Available in other architectural hardware finishes – consult factory